

Standard and Modular Centrifugal Untempered Supply Fans Installation, Operation, and Maintenance Manual

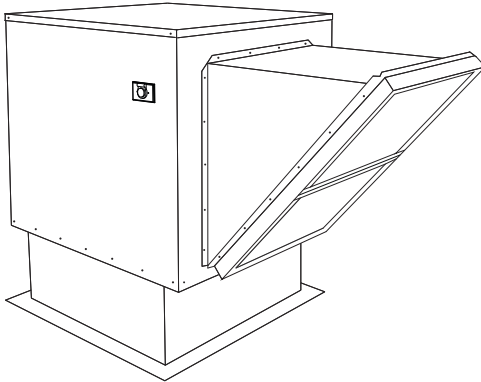

Standard Untempered Supply Fan

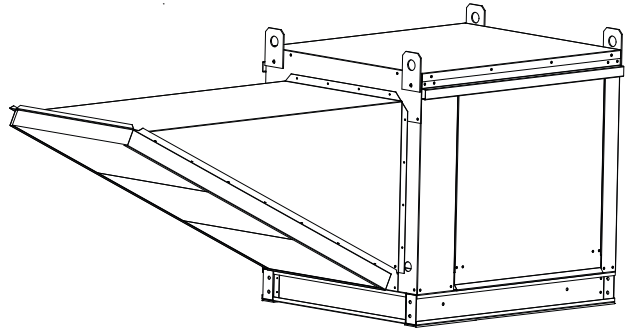

Modular Untempered Supply Fan

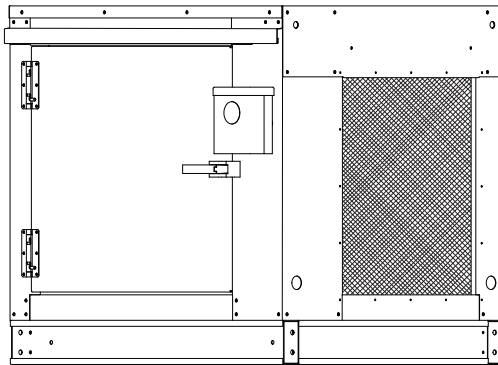

Inline Filtered Supply Fan



RECEIVING AND INSPECTION

Upon receiving unit, check for any interior and exterior damage. If damage is found, report it immediately to the carrier. Check that all accessory items are accounted for and are not damaged.

WARNING!!

Installation of this equipment should only be performed by a qualified professional who has read and understands these instructions and is familiar with proper safety precautions. Improper installation poses serious risk of injury due to electric shock and other potential hazards. Read this manual thoroughly before installing or servicing this equipment. **ALWAYS** disconnect power prior to working on equipment.

Save these instructions. This document is the property of the owner of this equipment and is required for future maintenance. Leave this document with the owner when installation or service is complete.

Table of Contents

WARRANTY	4
INSTALLATION	5
Mechanical	5
Site Preparation	5
Intake/Curb Assembly	6
Curb and Ductwork	7
Roof Mount Installation	8
Wall Mount Installation	10
Indoor (Inline) Installation	11
Installation with Exhaust Fan	11
Electrical	12
Fan to Building Wiring Connection	13
Motorized Intake Damper	14
Permanent Split Capacitor (PSC) Motor Speed Control	14
Electronically Commutated Motor (ECM) Speed Control	15
Unit Mount Controller	15
Motor Speed Controller (MSC) Installation	16
MSC Controls Overview	17
MSC Menu	17
Input Threshold	19
MSC Menu Tree	20
Variable Frequency Drive (VFD)	21
VFD Installation	22
Input AC Power	22
VFD Output Power	22
VFD Programming	23
ACTECH SMV VFD	24
START-UP OPERATION	25
Unit Start-up Procedure	25
Pulley Adjustment	26
Pulley Alignment/Proper Belt Tension	27
Pulley Combination Chart	28
Re-Circulating Control Options	29
Manual Positioning Control (Potentiometer)	29
Two Position Control	29
Building Signal Damper Control	29
Static Pressure Control (Photohelic)	29
Static Pressure Controller Installation Instructions	30
A-306 Outdoor Sensor	30
TROUBLESHOOTING	31
Airflow Troubleshooting Chart	31
MSC Troubleshooting	32
MAINTENANCE	33
General Maintenance	33
2 Weeks After Start-up	33
Every 3 Months	33
Yearly	33
Unit Filters	34
Start-up and Maintenance Documentation	36
Technical Support Information	36

WARRANTY

This equipment is warranted to be free from defects in materials and workmanship, under normal use and service, for a period of 2-years from date of shipment. This warranty shall not apply if:

1. The equipment is not installed by a qualified installer per the MANUFACTURER'S installation instructions shipped with the product.
2. The equipment is not installed in accordance with Federal, State, and Local codes and regulations.
3. The equipment is misused, neglected, or not maintained per the MANUFACTURER'S maintenance instructions.
4. The equipment is not installed and operated within the limitations set forth in this manual.
5. The invoice is not paid within the terms of the sales agreement.

The MANUFACTURER shall not be liable for incidental and consequential losses and damages potentially attributable to malfunctioning equipment. Should any part of the equipment prove to be defective in material or workmanship within the 2-year warranty period, upon examination by the MANUFACTURER, such part will be repaired or replaced by MANUFACTURER at no charge. The BUYER shall pay all labor costs incurred in connection with such repair or replacement. Equipment shall not be returned without MANUFACTURER'S prior authorization, and all returned equipment shall be shipped by the BUYER, freight prepaid to a destination determined by the MANUFACTURER.

INSTALLATION

It is imperative that this unit is installed and operated with the designed airflow and electrical supply in accordance with this manual. For warranty and technical support, refer to **page 36** for contact information.

Mechanical

WARNING: DO NOT RAISE UNIT BY THE INTAKE HOOD, BLOWER, MOTOR SHAFT, OR BEARINGS. USE ALL LIFTING LUGS PROVIDED WITH A SPREADER BAR OR SLING UNDER THE UNIT.

Clearance

The top, back, and front surfaces of this heater may not be installed less than 6" from combustible materials. The heater base may be installed on combustible surfaces. Allow 24" minimum service clearance on both sides of this heater.

Site Preparation

1. Provide clearance around installation site to safely rig and lift equipment into its final position (**Figure 1**). Supports must adequately support equipment. Refer to manufacturer's estimated weights.
2. Locate unit close to the space it will serve to reduce long, twisted duct runs.
3. Consider general service and installation space when locating unit.
4. Do not allow air intake to face prevailing winds. Support unit above ground or at roof level high enough to prevent precipitation from being drawn into its inlet. The inlet must also be located at least 10 feet away from any exhaust vents. The fan inlet shall be located in accordance with the applicable building code provisions for ventilation air.

Figure 1 - Spreader Bar

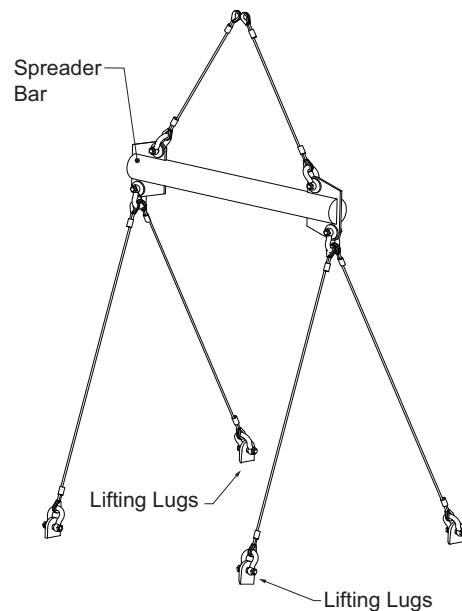

Intake/Curb Assembly

Filters and intake hoods for standard supply fans are shipped inside the supply fan housing for protection during shipping. Modular intakes are shipped on a separate skid. Upon unit arrival, follow these steps to assemble the intake to the fan:

1. Remove the fan top (standard supply fans only).
2. Remove the intake hood and filters from the fan housing.
3. Re-install the fan top (standard supply fans only).
4. Apply silicone or weather-proof gasket on the back side of the flanges of the intake hood.
5. Secure the flanges of the intake hood to the unit with the supplied sheet metal screws.
6. Use caulk on the outside of the screws to prevent water leaks.
7. Slide the filters down the filter track as shown.

Figure 2 - Intake Assembly

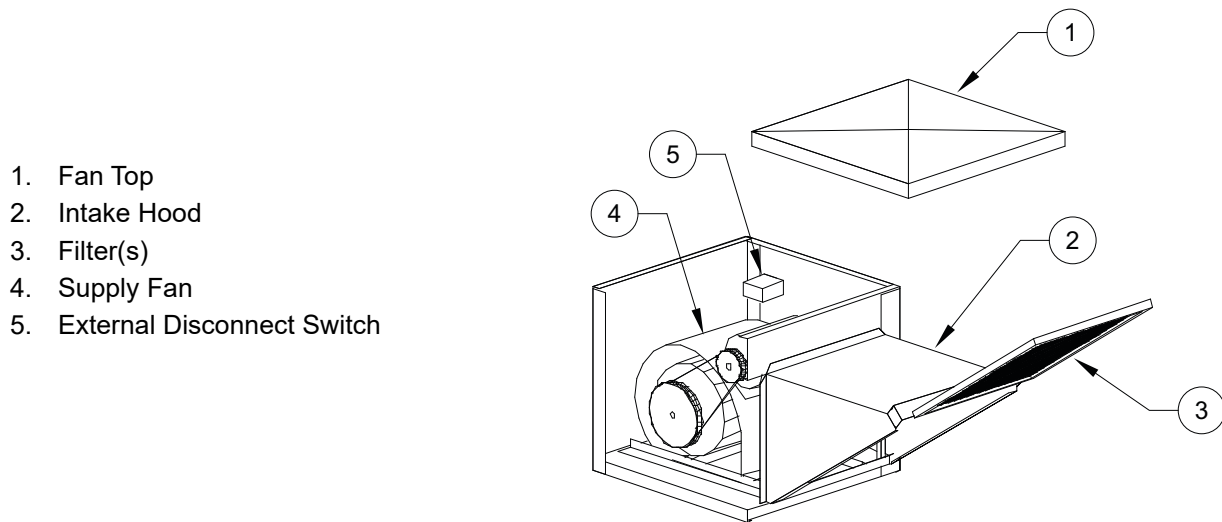

Curb and Ductwork

This fan was specified for a specific CFM and static pressure. The ductwork attached to this unit will significantly affect airflow performance. When using rectangular ductwork, elbows must be radius throat, radius back with turning vanes. Flexible ductwork and square elbows should not be used. Any transitions and/or turns in the ductwork near the fan outlet will cause system effect. System effect will drastically increase the static pressure and reduce airflow.

- **Table 1** displays the minimum fan outlet duct sizes and straight lengths recommended by the manufacturer for optimal fan performance. Failure to adhere to recommendations may cause performance issues and/or structural damage. Any unit damage caused by not adhering to recommended duct lengths will not be covered under warranty.
- Do not use the unit to support ductwork in any way. This may cause damage to the unit.
- **Follow SMACNA guides and manufacturer's requirements for the remaining duct run.** Fans designed for rooftop installation should be installed on a prefabricated or factory-built roof curb.
- Follow curb manufacturer's instructions for proper curb installation.
- The unit should be installed on a curb and/or rail that meets local code height requirements.
- Make sure the duct connection and fan outlet are properly aligned and sealed.
- Secure fan to curb through vertical portion of the ventilator base assembly flange. Use a minimum of eight (8) lug screws, anchor bolts, or other suitable fasteners (not furnished). Shims may be required depending upon curb installation and roofing material.
- Verify all fasteners are secure. **Figure 3** through **Figure 6** show different mechanical installations.

Table 1 - Required Supply Ductwork

Blower Size (Inches)	Discharge	Duct Size	Straight Duct Length
10	Side	14" x 14"	48"
	Down		
15D, 16Z, 18Z	Side	20" x 20"	72"
	Down	14" x 14"	48"
12	Side	16" x 16"	54"
	Down		
15	Side	20" x 20"	72"
	Down		
20D, 20Z, 22Z	Side	26" x 26"	108"
	Down	20" x 20"	72"
18	Side	24" x 24"	86"
	Down		
24D, 25Z	Side	30" x 30"	108"
	Down	24" x 24"	86"
20	Side	26" x 26"	108"
	Down		
30D, 28Z	Side	32" x 32"	168"
	Down	26" x 26"	108"
25	Side	32" x 32"	168"
	Down		
36D	Side	36" x 36"	189"
	Down	32" x 32"	168"

Roof Mount Installation

Note: Refer to submittal drawings for specific unit dimensions.

Figure 3 - Roof Mount Details

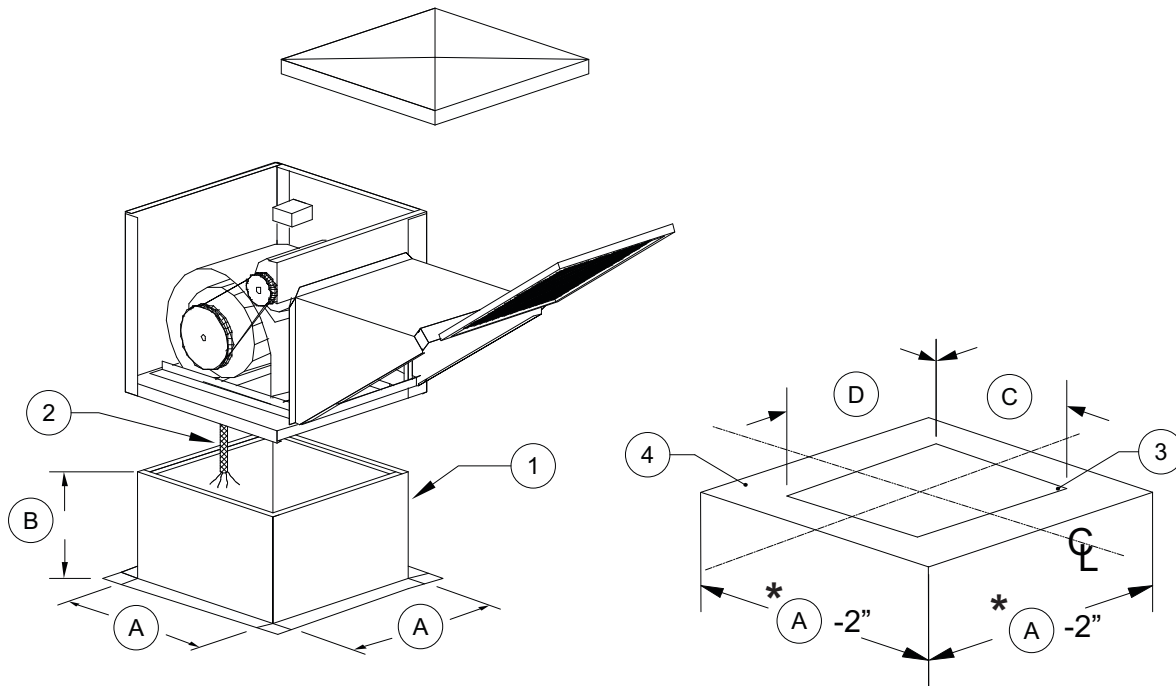

1. Curb
2. Electrical Drop
3. Blower Outlet Size
4. Roof Opening

- A. Curb Measurement, refer to **Table 2**
- B. Curb Height Measurement, refer to **Table 2**
- C. Roof Opening Measurement 1, refer to **Table 2**
- D. Roof Opening Measurement 2, refer to **Table 2**
- CL. Center Line

***Maximum roof opening 2" smaller then curb outside dimensions.**

Table 2 - Curb/Roof Top Dimensional Data

Standard Curb/Roof Top Dimensional Data					
Model	Blower Size (Inches)	A	B	C	D
Size 1	10	23"	14"	11-3/4"	13-1/2"
Size 2	12	32-1/2"	14"	11-3/4"	15-7/8"
	15			16-1/8"	18-7/8"

Modular Curb/Roof Top Belt Drive Dimensional Data					
Model	Blower Size (Inches)	A	B	C	D
Size 1	10	21"	20"	11-3/4"	13-1/2"
Size 2	12	31"	20"	13-3/4"	15-7/8"
	15			16-1/8"	18-7/8"
Size 3	18	35"	20"	18-7/8"	21-7/8"
Size 4	20	42"	20"	24-5/8"	24-5/8"
Size 5	25	52-1/2"	20"	31-1/8"	31-1/8"

Modular Curb/Roof Top Direct Drive Dimensional Data					
Model	Blower Size (Inches)	A	B	C	D
Size 1	15D, 16Z, 18Z	21"	20"	11-3/4"	13-1/2"
Size 2	20D, 20Z, 22Z	31"	20"	13-3/4"	15-7/8"
Size 3	24D, 25Z	35"	20"	18-7/8"	21-7/8"
Size 4	30D, 28Z	42"	20"	24-5/8"	24-5/8"
Size 5	36D	52-1/2"	20"	31-1/8"	31-1/8"

Wall Mount Installation

Note: Refer to submittal drawings for specific unit dimensions.

Figure 4 - Wall Mount Details

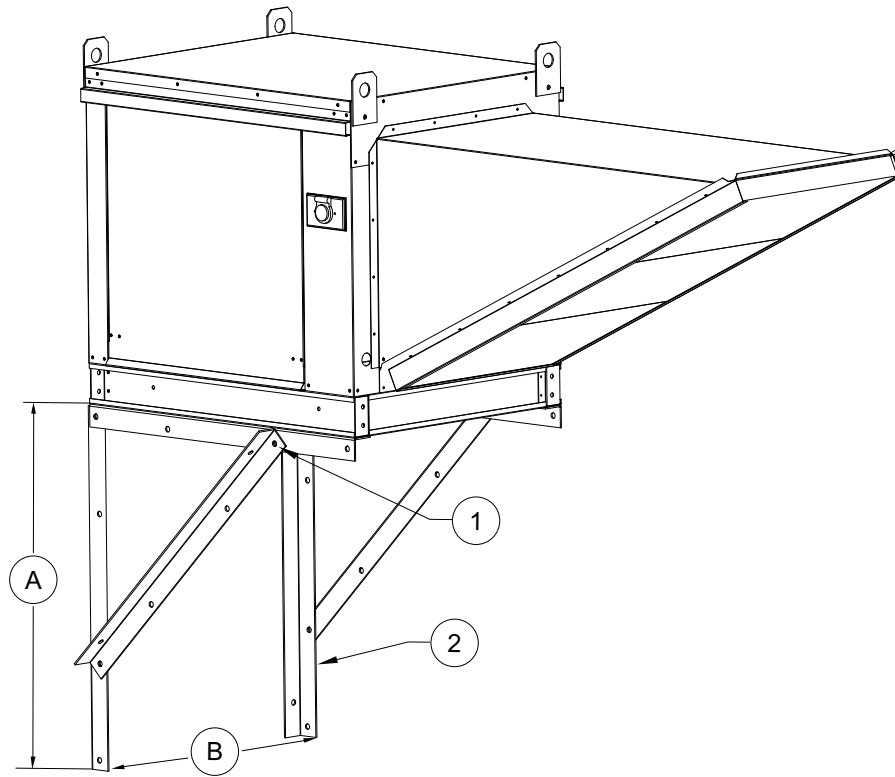

1. 1/2" Bolted Construction

2. 2" x 2" 10 Gauge Galvanized Angle

A. Mounting Height, refer to **Table 3**

B. Leg Spacing, refer to **Table 3**

Table 3 - Wall Mount Dimensional Data

Unit Size	Dimension A	Dimension B
1	32"	26"
2	40"	36"
3	45"	40"

Indoor (Inline) Installation

Note: Refer to submittal drawings for specific unit dimensions.

Figure 5 - Indoor (Inline) Details

1. Lifting Lugs
2. Uni-Strut Base
3. Intake Filter
4. Flex Conduit for Field Wiring
5. Disconnect Switch
6. Blower/Motor Access Door

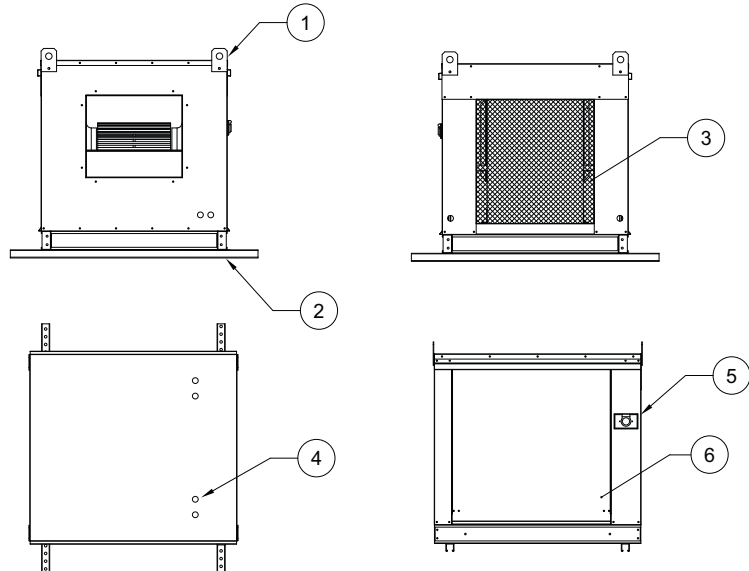

Installation with Exhaust Fan

Note: Refer to submittal drawings for specific unit dimensions.

Figure 6 - Exhaust Fan Details

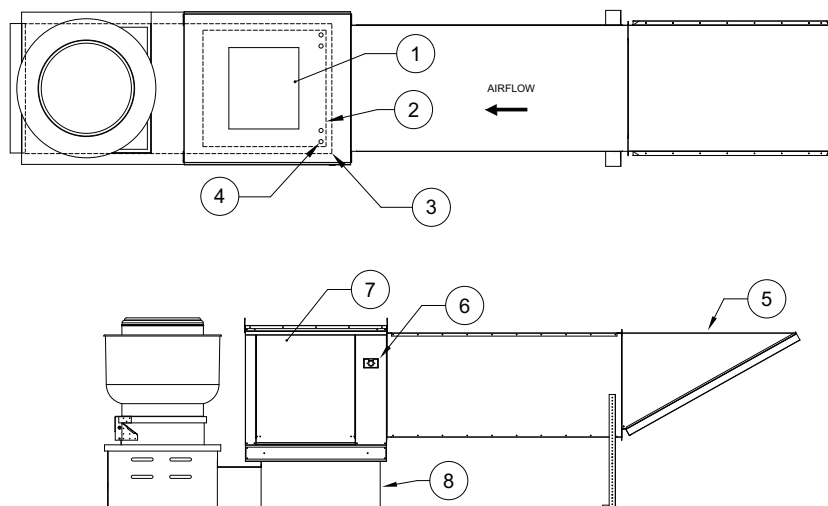

- | | |
|---|--|
| <ol style="list-style-type: none"> 1. Discharge Opening 2. Roof Opening 3. Curb Outer Wall 4. Flex Conduit for Field Wiring | <ol style="list-style-type: none"> 5. Sloped Intake Filter 6. Disconnect Switch 7. Blower/Motor Access Door 8. Curb with Support Legs or Rail (20" High) |
|---|--|

Electrical

WARNING!

Disconnect power before installing or servicing unit. High voltage electrical input is needed for this equipment. A qualified electrician should perform this work.

Before connecting power to the fan, read and understand the entire section of this document. As-built wiring diagrams are furnished with each unit by the factory and are attached to the control module's door or provided with paperwork packet.

Electrical wiring and connections must be made in accordance with local ordinances and the National Electric Code, ANSI/NFPA 70. Verify the voltage and phase of the power supply. Confirm the wire amperage capacity is in accordance with the unit nameplate. For additional safety information, refer to AMCA publication 410-96, *Recommended Safety Practices for Users and Installers of Industrial and Commercial Fans*.

1. **Always disconnect power before working on or near this equipment. Lock and tag the disconnect switch and/or breaker to prevent accidental power-up.**
2. An electrical drop containing the line voltage power wiring is shipped with every unit. The electrical drop should be brought through one of the conduit openings located in the base of the unit (**Figure 3**). Run the drop through the curb, and connect to a junction box inside the building.
3. A dedicated branch circuit should supply the motor circuit with short circuit protection according to the National Electric Code. This dedicated branch should run to the junction box. Every branch circuit should include a properly sized ground connection.
4. Verify that the power source is compatible with the requirements of your equipment. The nameplate identifies the **proper phase and voltage** of the equipment.
5. Before connecting the unit to the building's power source, verify that the power source wiring is de-energized. Refer to "**Fan to Building Wiring Connection**" on page 13.
6. Secure the power cable to prevent contact with sharp objects. Verify ground connection is secure.
7. Do not kink power cable and never allow the cable to encounter oil, grease, hot surfaces, or chemicals.
8. Before powering up the unit, make sure that the . Make sure that the interior of the unit is free of loose debris or shipping materials.
9. Electrically Commutated Motors (ECMs) and Variable Frequency Drives (VFDs) should not be powered through a Ground Fault Circuit Interrupter (GFCI) breaker/outlet. Unnecessary and intermittent tripping may occur.
10. If any of the original wire supplied with the unit must be replaced, it must be replaced with type THHN wire or equivalent.

Table 4 - Copper Wire Ampacity

Wire Size AWG	Maximum Amps
14	15
12	20
10	30
8	50
6	65
4	85
3	100
2	115
1	130

Fan to Building Wiring Connection

Figure 7 - Wiring Connection Details

120V Optional

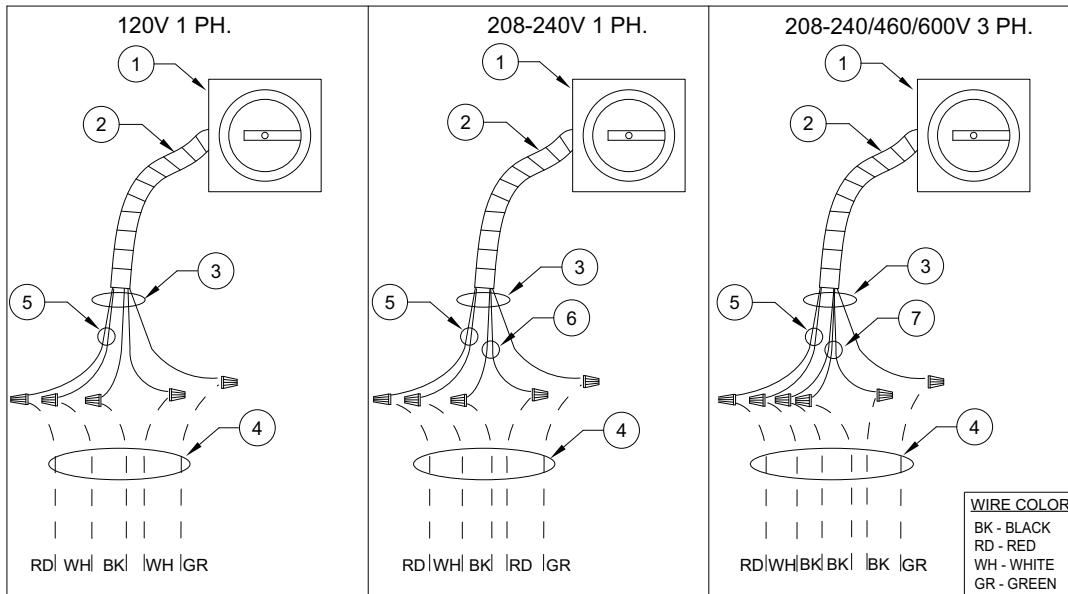

1. Disconnect Switch
2. Galflex Conduit (In Unit)
3. Factory Wiring
4. Field Supplied Wiring - From building power or pre-wired control panel.
5. 120V Single Phase Standing Power
6. 208-240 Single Phase
7. Three Phase

Motorized Intake Damper

On units shipped with the optional motorized intake damper, a power transformer is supplied with the unit if the main incoming voltage is greater than 120V. The damper motor is automatically energized when the main disconnect switch is in the ON position. No external wiring to the damper motor is required.

Permanent Split Capacitor (PSC) Motor Speed Control

Some single-phase direct-drive fans contain speed controls that regulate the amount of voltage going to the motor. Specific PSC motors must be used in conjunction with speed controls. The speed control has a knob (**Figure 8**) with an off position along with high to low range. At high speed, the speed control allows all of the line voltage to pass directly to the motor.

A minimum speed adjustment is provided to allow independent control of the minimum speed setting. Minimum speed adjustment ensures the motor runs with sufficient torque to prevent stalling. To adjust this:

1. Motor must be in actual operating conditions to achieve proper speed adjustment. Motor will not slow down unless proper load is applied.
2. Turn main control knob to lowest speed position.
3. Locate and adjust minimum speed setting. This can be found under the speed control faceplate. Use a small screwdriver to adjust. Rotate clockwise to decrease minimum speed; counter-clockwise to increase minimum speed.
4. Motor will now operate from this preset minimum speed to full speed.

The lowest minimum voltage that may be applied to these motors is 65V AC. Running lower voltages to the motor can cause premature failure and overheating problems.

Figure 8 - PSC Motor Speed Control

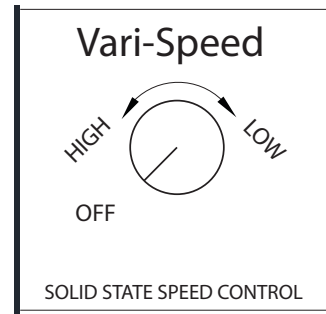

Electronically Commutated Motor (ECM) Speed Control

An Electronically Commutated Motor (ECM) with speed control allows for an accurate manual adjustment of the fan's speed. The benefits of using an EC motor is exceptional efficiency, performance, and motor life. ECMs should not be powered through a Ground Fault Circuit Interrupter (GFCI) breaker/outlet. Unnecessary and intermittent tripping may occur.

Unit Mount Controller

The RTC speed controller features a 4 digit LED display with a five button interface. All parameters can be accessed through the user menu. The percent of run speed can be changed by using the **Up** and **Down** buttons followed by pressing **Enter** (middle button) to save changes. Every **ten seconds** the display will toggle between current percentage of run speed and current RPMs. The flow index has a range of **0-100%** and is typically linear with motor RPM.

If the remote function (re) is enabled, the speed is controlled through a **0-10V** input. **0V = 0%** and **10V = 100%**, unless overridden by the low speed and high speed limits.

The speed controller requires a **24V AC** input and can locally turn the motor on and off. The motor RPM range is fully adjustable between the minimum and maximum setpoints, see LSPD and HSPD on the programming display. For more information, see the RTC control operating manual.

For all motors except 16Z, 18Z, 20Z, 22Z, 25Z, 28Z: If "oFF" is being displayed, and the speed is set above 300 RPM, the ECM is not receiving RPM feedback. Check that the ECM is wired correctly. Check that the motor "tyP" in the settings matches the motor manufacturer. 16Z, 18Z, 20Z, 22Z, 25Z, 28Z do not send RPM feedback.

NOTE: A Variable Frequency Drive (VFD) is required to adjust the speed control of a non-electrically commutated 3-phase direct-drive motor.

Figure 9 - RTC Speed Controller and Menu

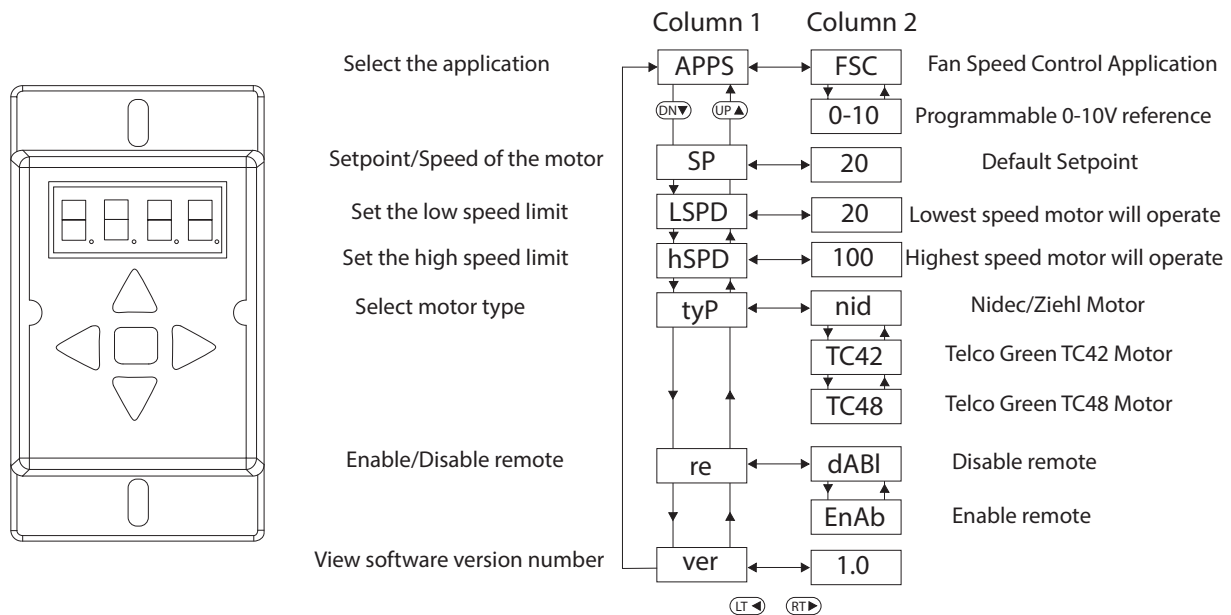

Motor Speed Controller (MSC) Installation

The Motor Speed Controller (MSC) is a versatile device able to output various signal types to many different Electrically Commutated Motors (ECMs). The MSC signal output types can be selected under the 'Motor Type' section of the MSC menu. The MSC may be installed in a fan, remotely in a kitchen space, or in a mechanical room. While this device can be mounted remotely and powered using 24V, it may also be mounted with the fan where it will be exposed to higher voltages. If installed in the fan, the electrical installation must be carried out according to the appropriate regulations (e.g., cable cross-sections, circuit breaker, protective earth [PE] connection). National and local codes must be followed during the installation process.

The MSC board may be powered through a 120VAC/24VAC CLASS 2 transformer, 120V AC/24V DC CLASS 2 power supply, or through MODBUS connections.

The MSC contains static sensitive components. Therefore, you must handle with care to avoid damage to these components. All operations concerning installation, commissioning, and maintenance must be carried out by qualified, skilled personnel who are familiar with the installation, assembly, commissioning, and operation of the electronic board and the application for which it is being used.

Ensure proper handling and avoid excessive mechanical stress. Do not bend any components when handling or installing component. **Do not touch any electronic components or contacts.**

Precautions must be adhered to during installation, testing, servicing, and repairing of this board. Component damage may result if proper procedures are not followed.

Do not install the MSC where it is subjected to adverse environmental conditions such as combustibles, oils, hazardous vapors, corrosive chemicals, excessive dust, moisture, direct sunlight, or extreme temperatures. When removing or installing the MSC to the j-box, verify the gasket is present. All electrical connections for the MSC are located on the backside of the controller. Refer to **Figure 10** for details on installation and electrical connections. When the micro USB programming port is not in use, place the weather-seal plug into the port location.

Figure 10 - Installation/Electrical Connections

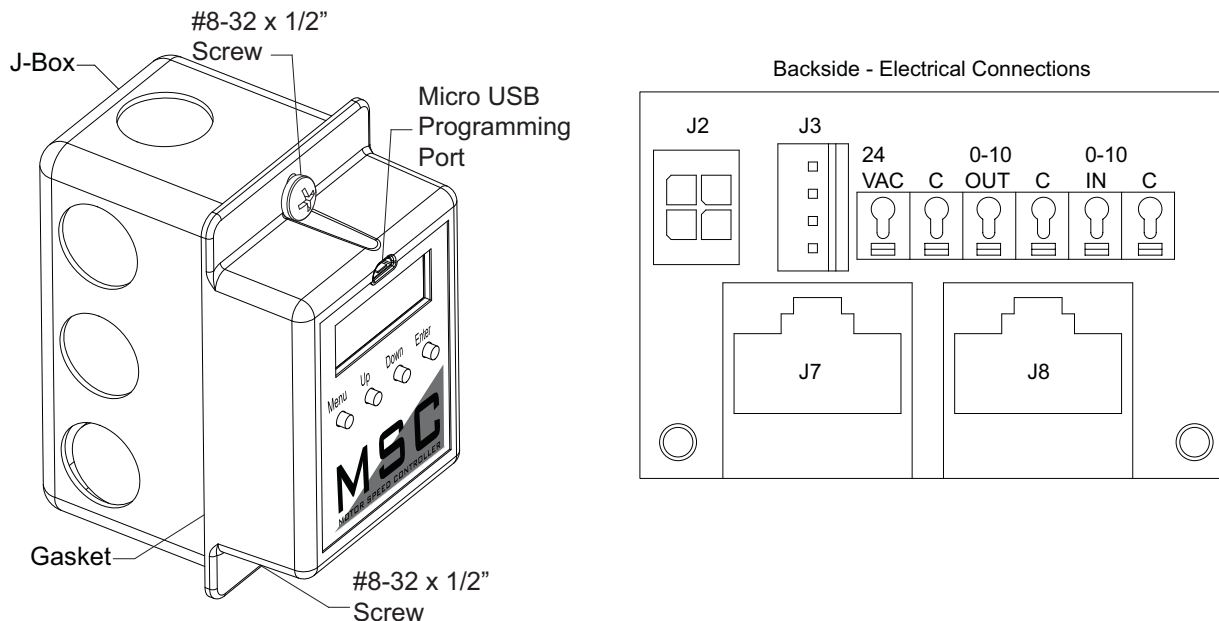

MSC Controls Overview

There are four buttons to navigate through the menu screens, refer to **Figure 11**.

Press the **MENU** button to access menu settings/parameters, pressing **MENU** will also back out of the current menu screen. To scroll through menus, use **UP** and **DOWN** buttons. Press the **ENTER** button to change setting/parameter selection.

To enter password, press MENU, then press **ENTER** when "Board Config" is displayed. Use **UP** and **DOWN** to scroll through numbers, press **ENTER** to advance to the next numerical setting. To save changes, press **MENU** until the screen displays "SAVE CHANGES? [ENTER] TO SAVE." Press the ENTER button to save changes.

Figure 11 - MSC Front Detail View

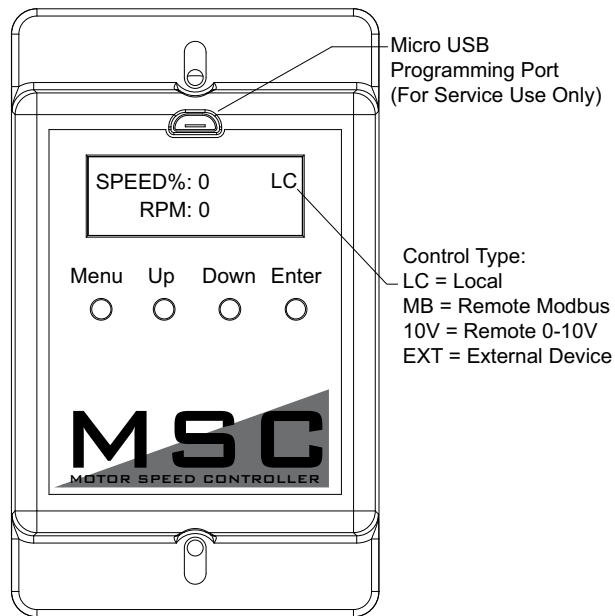

MSC Menu

Board Config - Password (default is 0225)

- **Motor Type** - User may change motor type between Nidec, Telco 42, Telco 48, Ziehl, 0-10V, Other.
- **Control Type** - This setting adjusts how the fan will be controlled.
 - **Local** - The fan will be controlled by the MSC.
 - **Remote Modbus** - The fan will be controlled by another master board through the MSC. A connection between the 0-10V Out to 0-10V In must be made for start command.
 - **Remote 0-10V** - The fan will be controlled by an external 0-10V signal.
- **Speed Settings** - Provides access to speed and voltage settings.
 - **Low Speed** - Adjustable speed from 20% up to high speed setting, or 0-10V. Setting cannot go above High Speed parameter.
 - **High Speed** - Adjustable speed from 100% down to low speed setting, or 0-10V. Setting cannot go below Low Speed parameter.
 - **Set Speed%** - Adjustable speed range is dependent on Low Speed and High Speed settings. This controls the output of the motor.
 - **Voltage Range** - Only available when Motor Type "OTHER" is selected. Default setting is 24V. 5V, and 10V are also available.

- **Modbus #** - Adjustable Modbus ID. Exhaust Fan range 11-18, Supply Fan range 21 or 22. **A VFD and MSC cannot use the same Modbus #.**
- **Options**
 - **Feedback Fault** - If set to ENABLED, the MSC will monitor RPM feedback. If the MSC does not receive data for 30 seconds or 70% of the expected RPM, this fault will be displayed. **Ziehl motors do not provide feedback.**
 - **2 Speed** - The 0-10V output cannot be used when the 2 Speed or Manual Speed options are On, or if the "Control Type" is set to Modbus. When the 0-10V OUT and 0-10V IN terminals are **not** jumped together, the fan will operate at low speed. When 0-10V OUT and 0-10V IN terminals are jumped together, the fan will operate at high speed.
 - **Analog Speed** - The user may enable/disable the option, and calibrate a potentiometer for proper operation that is connected between the 0-10V OUT and 0-10V IN terminals. When enabled, you must calibrate the potentiometer. Follow the MSC's on-screen instructions. The speed will be adjustable between 0V (low speed) to 10V (high speed).
 - **Input Threshold** - When control type is set to Remote 0-10V, an input threshold will be created for motor control. Refer to **Figure 12 on page 19** for threshold examples.
 - **Zero Operation** - The user may select how the motor will operate when the 0-10V input is at 0V. The options will be Off or Low Speed (default).
 - **Threshold** - Increasing the threshold value will allow for the device to hold its voltage/RPM output while the input is between the 0 - threshold value.
 - **Restore Settings** - Provides access to restore factory settings, and test & balance settings.
 - **Factory Settings** - This will reset all values back to factory settings.
 - **T & B Settings** - This will reset all values back to last saved test & balance settings.
 - **Change Password** - Users may update the password setting to their own. Password 0225 will also be stored for backup. Both passwords will allow users to enter "Board Config" settings.

Software Version - Displays the current software version installed on the board.

Faults - This provides access to "Fault History," "Fault Totals," and "Clear Faults."

- **Fault History** - Displays fault history and board reboots in chronological order. Possible displayed faults are:
 - **No Faults** - There are no active faults with the system.
 - **Feedback Fault** - Only displayed for motors with feedback capabilities.
 - **Reboot** - Any time the fan goes from OFF to ON, this "fault" will be logged. This fault will only display in "Fault History."
 - **Modbus** - Issue with Modbus communication between the MSC and master board.
 - **Variable Device Fault** - When "Analog Speed" is selected and a potentiometer is connected, if the voltage drops below 1V, this fault will be displayed.
- **Fault Totals** - Displays amount of faults for Modbus, Feedback, Var Device, Reboot, and Total Faults.
- **Clear Faults** - Users may clear all faults from the board.

Service - This provides access to service settings. Password: 1234

- **Save T & B** - After the test & balance process has been completed, save adjustments under this menu.
- **IO Status** - Provides access to information about the inputs and outputs of the MSC board.
 - **V In** - Displays the incoming voltage (0-10V) to the MSC.
 - **V Out** - Displays the output voltage (0-10V) to the motor.
 - **RPM** - Displays motor RPM feedback. **Ziehl motors do not provide feedback.**
 - **PWM V** - Displays equivalent voltage reading of the PWM output to the motor.
 - **Speed%** - Displays PWM percentage output value to the motor.

Input Threshold

Figure 12 - Input Threshold Examples

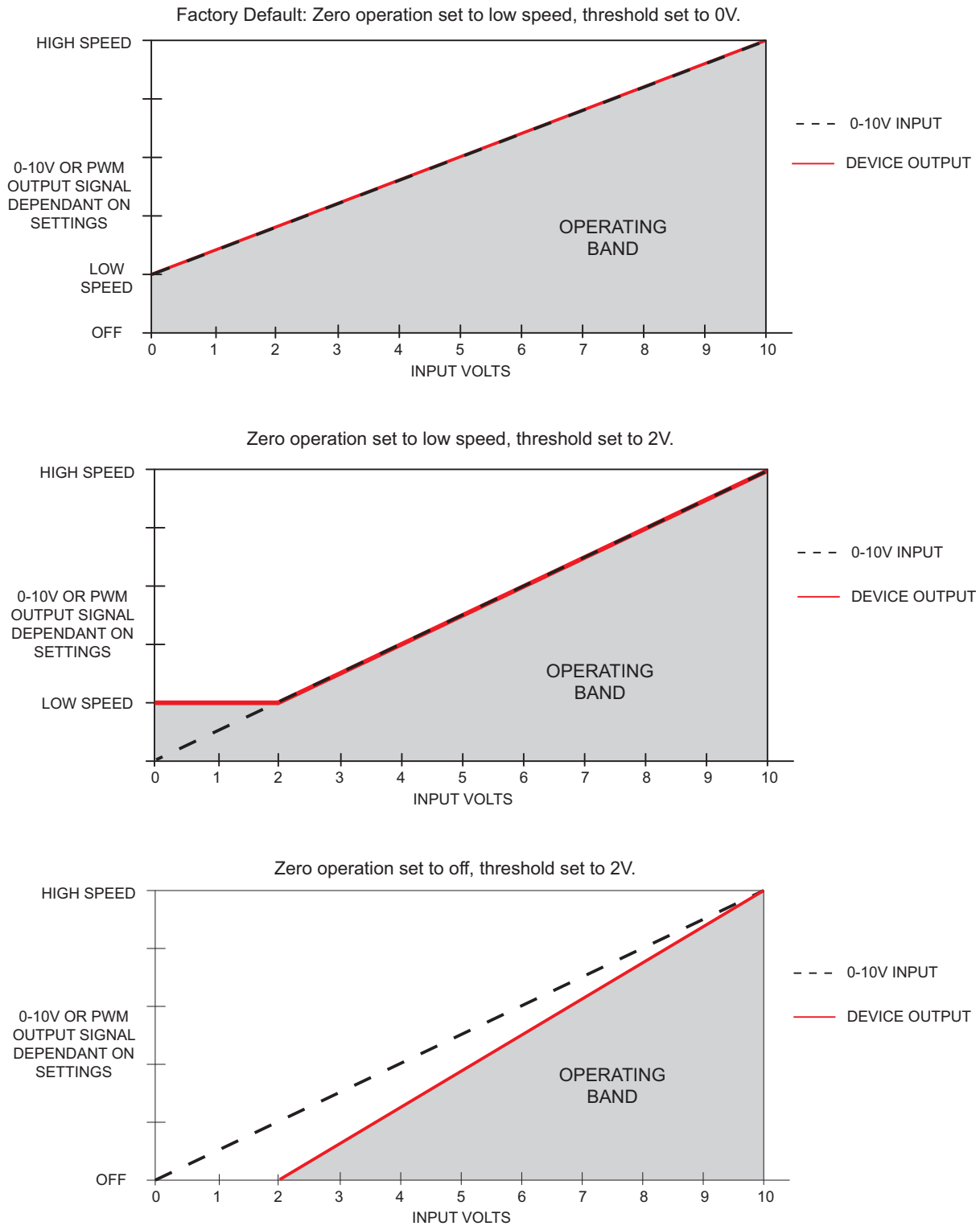

MSC Menu Tree

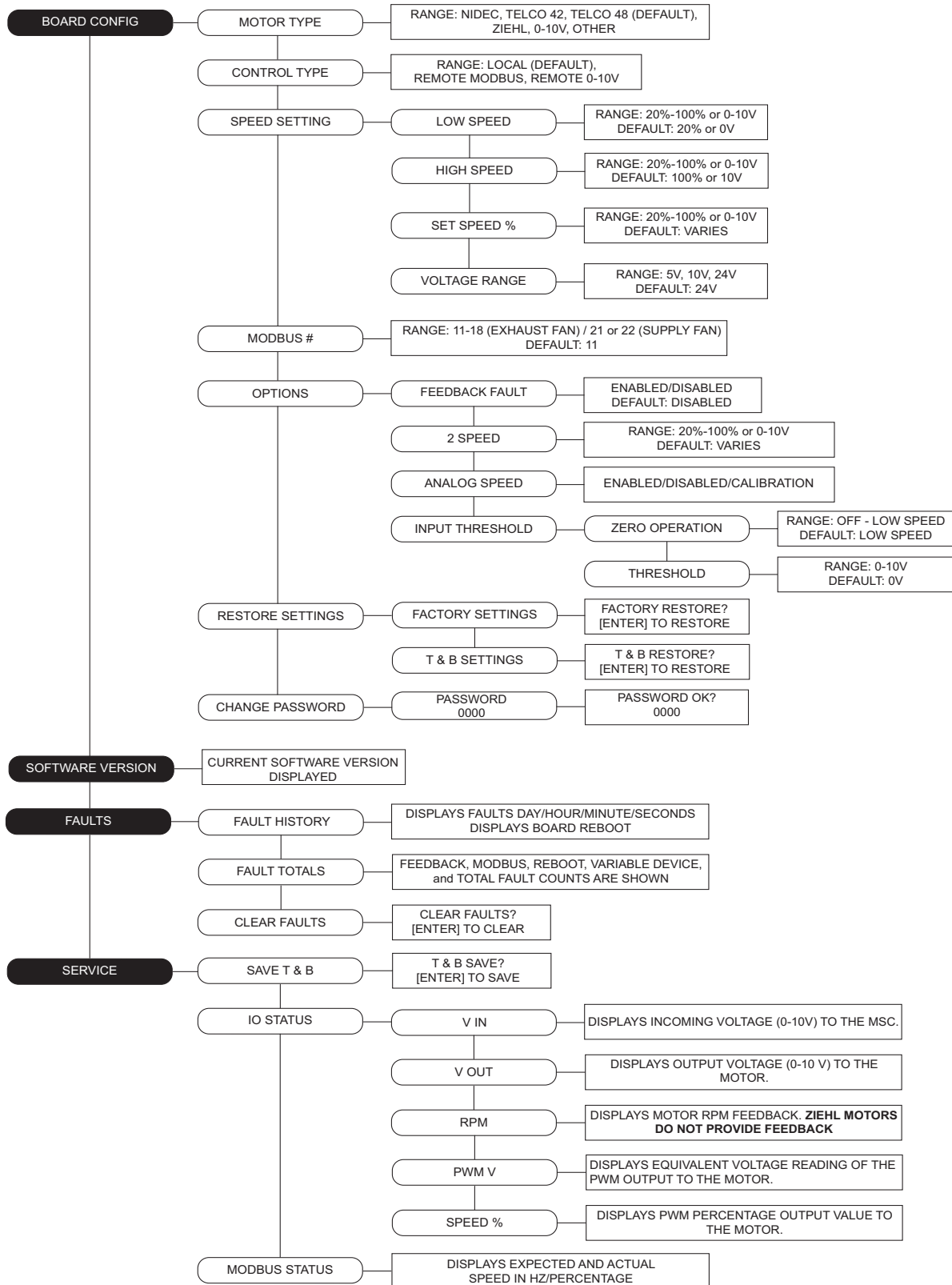

Variable Frequency Drive (VFD)

WARNING!

- Before installing the VFD drive, ensure the input power supply to the drive is OFF.
- The power supply and motor wiring of the VFD must be completed by a qualified electrician.
- The VFD is factory programmed, only change if replaced or ordered separately.

Not suitable for corner grounded 3 phase input power. Consult the VFD manual and all documentation shipped with the unit for proper installation and wiring of the VFD. The VFD has been programmed by the factory with ordered specific parameters. Use **Table 5** as a guide during installation.

Table 5 - VFD Installation Check List

Check Off	Description
	The installation environment conforms to the VFD manual.
	The drive is mounted securely.
	Space around the drive meets the drive's specification for cooling.
	The motor and driven equipment are ready to start.
	The drive is properly grounded.
	The input power voltage matches the drive's nominal input voltage.
	The input power connections at L1, L2, and L3 are connected and tight. Verify correct size crimp fitting is used.
	The input power protection is installed.
	The motor's power connection at U, V, and W are connected and tight. Verify correct size crimp fitting is used.
	The input, motor, and control wiring are run in separate conduit runs.
	The control wiring is connected and tight.
	NO tools or foreign objects (such as drill shavings) are in the drive.
	NO alternative power source for the motor (such as a bypass connection) is connected - NO voltage is applied to the output of the drive.

VFD Installation

Input AC Power

- Circuit breakers feeding the VFDs are recommended to be thermal-magnetic and fast-acting. They should be sized based on the VFD amperage. Refer to “**ACTECH SMV VFD**” on page 24. See installation schematic for exact breaker sizing.
- Every VFD should receive power from its own breaker. If multiple VFDs are to be combined on the same breaker, each drive should have its own protection measure (fuses or miniature circuit breaker) downstream from the breaker.
- Input AC line wires should be routed in conduit from the breaker panel to the drives. AC input power to multiple VFDs can be run in a single conduit if needed. **Do not combine input and output power cables in the same conduit.**
- The VFD should be grounded on the terminal marked PE. A separate insulated ground wire must be provided to each VFD from the electrical panel. This will reduce the noise being radiated in other equipment.
- VFDs should not be powered through a Ground Fault Circuit Interrupter (GFCI) breaker/outlet. Unnecessary and intermittent tripping may occur.

ATTENTION: Do not connect incoming AC power to output terminals U, V, W. Severe damage to the drive will result. Input power must always be wired to the input L terminal connections (L1, L2, L3).

VFD Output Power

- Motor wires from each VFD to its respective motor **MUST** be routed in a **separate steel** conduit away from control wiring and incoming AC power wiring. This is to avoid noise and crosstalk between drives. An insulated ground must be run from each VFD to its respective motor. Do not run different fan output power cables in the same conduit.
- VFD mounted in ECP: A load reactor should be used and sized accordingly when the distance between the VFD and motor is greater than specified below. The load reactor should be installed within 10 feet of the VFD output:
 - 208/230V** - Load reactor should be used when distance exceeds 250 feet.
 - 460/480V** - Load reactor should be used when distance exceeds 50 feet.
 - 575/600V** - Load reactor should be used when distance exceeds 25 feet.
- VFD mounted in fan: The load reactor should be sized accordingly when the VFD is mounted in the fan.
 - 208/230V** - Load reactor is optional but recommended for 15 HP and above motors.
 - 460/480V** - Load reactor is optional but recommended for 7.5 HP and above motors.
 - 575/600V** - Load reactors are required for all HP motors.
- If the distance between the VFD and the motor is extremely long, up to 1000 FT, a dV/dT filter should be used, and the VFD should be increased by 1 HP or to the next size VFD. The dV/dT filter should be sized accordingly and installed within 10 feet of the output of the VFD.
 - 208/230V** – dV/dT filter should be used when distance exceeds 400 feet.
 - 460/480V** – dV/dT filter should be used when distance exceeds 250 feet.
 - 575/600V** – dV/dT filter should be used when distance exceeds 150 feet.
- Do not install a contactor between the drive and the motor. Operating such a device while the drive is running can potentially cause damage to the power components of the drive.
- When a disconnect switch is installed between the drive and motor, the disconnect should only be operated when the drive is in a STOP state.

VFD Programming

Programming

1. The Drive should be programmed for the proper motor voltage. P107 is set to 0 (Low) if motor voltage is 120V AC, 208V AC or 400V AC. P107 is set to 1 (High) if the motor voltage is 230V AC, 480V AC, or 575V AC.
2. The Drive should be programmed for the proper motor overload value. P108 is calculated as Motor FLA x 100 / Drive Output Rating (refer to “**ACTECH SMV VFD**” on page 24).

To enter the PROGRAM mode to access the parameters:

1. Use the buttons on the VFD screen (**Figure 13**) to adjust VFD settings. Press the Mode (M) button. This will activate the password prompt (PASS).
2. Use the Up and Down buttons to scroll to the password value (the factory default password is “0225”) and press the Mode (M) button. Once the correct password is entered, the display will read “P100”, which indicates that the PROGRAM mode has been accessed at the beginning of the parameter menu.
3. Use the Up and Down buttons to scroll to the desired parameter number.
4. Once the desired parameter is found, press the Mode (M) button to display the present parameter setting. The parameter value will begin blinking, indicating that the present parameter setting is being displayed. The value of the parameter can be changed by using the Up and Down buttons.
5. Pressing the Mode (M) button will store the new setting and exit the PROGRAM mode. To change another parameter, press the Mode (M) button again to re-enter the PROGRAM mode. If the Mode button is pressed within 1 minute of exiting the PROGRAM mode, the password is not required to access the parameters. After one minute, the password must be re-entered to access the parameters again.

P500 parameter provides a history of the last 8 faults on the drive. It can be accessed without entering PROGRAM mode.

Figure 13 - VFD Screen

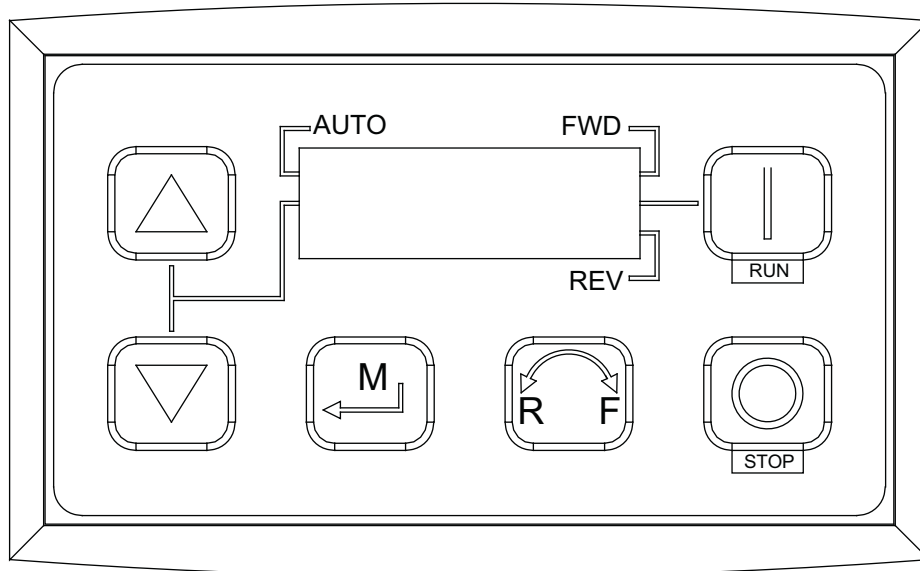

NOTE: When a parameter is changed in the drive, the drive should be de-energized. Wait for the display to go completely dark. Once the display is completely dark, the drive can be re-energized.

ACTECH SMV VFD

Table 6 - Cross-Reference

HP	Part Number	Volts	1Ø Input	3Ø Input	Input Amps 1Ø 120V AC	Input Amps 1Ø 240V AC	Output Amps	Breaker 1Ø 120V AC	Breaker 1Ø 240V AC
0.5	ESV371N01SXB	120/240V	X	-	9.2	4.6	2.4	15	15
1	ESV751N01SXB	120/240V	X	-	16.6	8.3	4.2	25	15
1.5	ESV112N01SXB	120/240V	X	-	20	10	6	30	20

HP	Part Number	Volts	1Ø Input	3Ø Input	Input Amps 1Ø	Input Amps 3Ø	Output Amps	Breaker 1Ø	Breaker 3Ø
0.5	ESV371N02YXB	240V	X	X	5.1	2.9	2.4	15	15
1	ESV751N02YXB	240V	X	X	8.8	5	4.2	15	15
1.5	ESV112N02YXB	240V	X	X	12	6.9	6	20	15
2	ESV152N02YXB	240V	X	X	13.3	8.1	7	25	15
3	ESV222N02YXB	240V	X	X	17.1	10.8	9.6	30	20
5	ESV402N02TXB	240V	-	X	-	18.6	16.5	-	30
7.5	ESV552N02TXB	240V	-	X	-	26	23	-	40
10	ESV752N02TXB	240V	-	X	-	33	29	-	50
15	ESV113N02TXB	240V	-	X	-	48	42	-	80
20	ESV153N02TXB	240V	-	X	-	59	54	-	90
480V									
1	ESV751N04TXB	480V	-	X	-	2.5	2.1	-	15
1.5	ESV112N04TXB	480V	-	X	-	3.6	3	-	15
2	ESV152N04TXB	480V	-	X	-	4.1	3.5	-	15
3	ESV222N04TXB	480V	-	X	-	5.4	4.8	-	15
5	ESV402N04TXB	480V	-	X	-	9.3	8.2	-	15
7.5	ESV552N04TXB	480V	-	X	-	12.4	11	-	20
10	ESV752N04TXB	480V	-	X	-	15.8	14	-	25
15	ESV113N04TXB	480V	-	X	-	24	21	-	40
20	ESV153N04TXB	480V	-	X	-	31	27	-	50
25	ESV183N04TXB	480V	-	X	-	38	34	-	70
30	ESV223N04TXB	480V	-	X	-	45	40	-	80
40	ESV303N04TXB	480V	-	X	-	59	52	-	100
50	ESV373N04TXB	480V	-	X	-	74	65	-	125
60	ESV453N04TXB	480V	-	X	-	87	77	-	150
600V									
1	ESV751N06TXB	600V	-	X	-	2	1.7	-	15
2	ESV152N06TXB	600V	-	X	-	3.2	2.7	-	15
3	ESV222N06TXB	600V	-	X	-	4.4	3.9	-	15
5	ESV402N06TXB	600V	-	X	-	6.8	6.1	-	15
7.5	ESV552N06TXB	600V	-	X	-	10.2	9	-	20
10	ESV752N06TXB	600V	-	X	-	12.4	11	-	20
15	ESV113N06TXB	600V	-	X	-	19.7	17	-	30
20	ESV153N06TXB	600V	-	X	-	25	22	-	40
25	ESV183N06TXB	600V	-	X	-	31	27	-	50
30	ESV223N06TXB	600V	-	X	-	36	32	-	60
40	ESV303N06TXB	600V	-	X	-	47	41	-	70
50	ESV373N06TXB	600V	-	X	-	59	52	-	90
60	ESV453N06TXB	600V	-	X	-	71	62	-	110

START-UP OPERATION

Before starting up or operating the unit, verify all fasteners are secure and tight. Check the set screw in the wheel hub. With power **OFF** to the unit or before connecting the unit to power, turn the fan wheel by hand. Verify it is not striking the inlet or any obstructions. If necessary, re-center.

Special Tools Required: Standard Hand Tools, AC Voltage Meter, Tachometer

Unit Start-up Procedure

1. Check all electrical connections are secure and tight.
2. Inspect the condition of the intake damper and damper linkage, if applicable.
3. Remove intake filters if not already installed, inspect the air stream for obstructions. Install intake filters.
4. Compare the supplied **motor voltage** with the fan's nameplate voltage. If this does not match, correct the problem.
5. Place the external disconnect to the **ON** position to start the unit. Immediately place the disconnect switch off. **Check the rotation of the fan** with the directional arrow on the blower scroll. Reversed rotation will result in poor air performance, motor overloading and possible burnout. For units equipped with a single-phase motor, check the motor wiring diagram to change rotation. For 3-phase motors, any two power leads can be interchanged to reverse motor direction.
6. When the fan is started, observe the operation and check for any unusual noises.
7. Place the external disconnect switch back to the **ON** position. The system should be in full operation with all ducts attached. Measure the system airflow.
8. Once the proper airflow is achieved, measure and record the fan speed with a reliable tachometer. **Caution - Excessive speed will result in motor overloading or bearing failure. Do not set fan RPMs higher than specified in the maximum RPM chart.** Refer to “TROUBLESHOOTING” on page 31 for more information.
9. Measure and record the **voltage** and **amperage** to the motor. Compare with the motor's nameplate to determine if the motor is operating under safe load conditions.

Pulley Adjustment

The adjustable motor pulley is factory set for the RPM specified (**Table 7**). Speed can be increased by closing or decreased by opening the adjustable motor sheave. Two groove variable pitch pulleys must be adjusted to an equal number of turns open or closed. Any increase in speed represents a substantial increase in horsepower required by the unit. Motor amperage should always be checked to avoid serious damage to the motor when the speed is varied. Always torque set screws according to the torque specifications shown in **Figure 14**.

Figure 14 - Adjustable Pulley

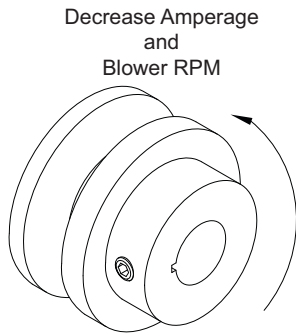

Setscrew Thread Size	Torque (in-lbs)
No. 10 (bushing)	32
1/4" (bushing)	72
5/16"	130

Table 7 - Maximum RPM and HP Chart

Blower Size	Max. RPM	Max. HP
10"	1800	2
12"	1500	3
15"	1400	5
18"	1200	5
20"	1000	10
25"	900	20

Pulley Alignment/Proper Belt Tension

- Belts tend to stretch and settle into pulleys after an initial start-up sequence. **Do not tension belts by changing the setting of the motor pulley**, this will change the fan speed and may damage the motor.
 - To re-tension belts, turn OFF power to the fan motor.
 - Loosen all fasteners that hold the blower motor plate to the blower housing.
 - Rotate the motor to the left or right to adjust the belt tension. Belt tension should be adjusted to allow 1/64" of deflection per inch of belt span. Use extreme care when adjusting V-belts as not to misalign pulleys. Any misalignment will cause a sharp reduction in belt life and produce squeaky noises. Over-tightening will cause excessive belt and bearing wear as well as noise. Too little tension will cause slippage at start-up and uneven wear.
 - Whenever belts are removed or installed, never force belts over pulleys without loosening motor first to relieve belt tension.** When replacing belts, use the same type as supplied by the manufacturer. On units shipped with double groove pulleys, matched belts should always be used.
- All fasteners should be checked for tightness each time maintenance checks are performed before restarting unit.

Belt tension examples:

- Belt span 12" = 3/16" deflection
- Belt span 32" = 1/2" deflection

Figure 15 - Pulley Alignment/Belt Tension

- A. Belt Span Length
- B. Deflection
- C. Center Distance

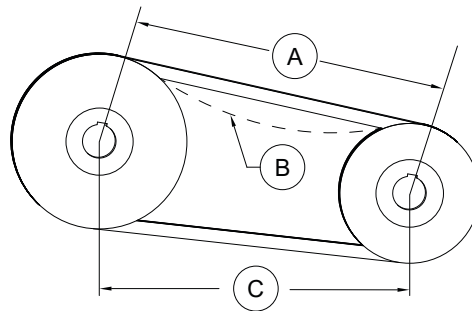

Correct

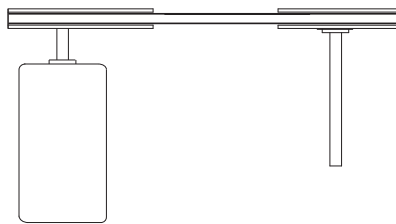

Incorrect

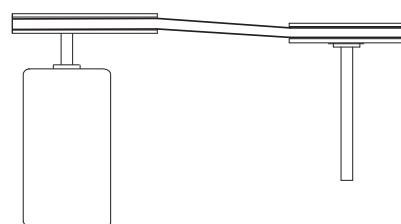

Incorrect

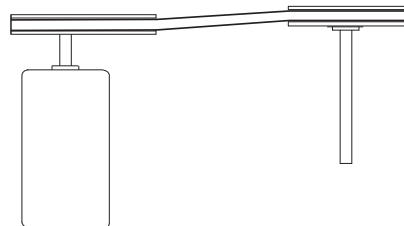

Incorrect

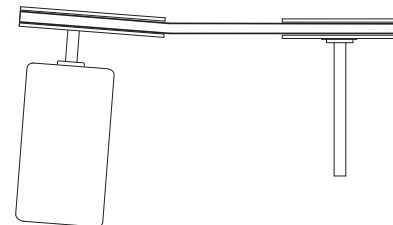

Pulley Combination Chart

Motor RPM			1725												
1/3 to 1-1/2 HP AX BELTS			MOTOR PULLEY 1VL34		Dd1 1.9	Dd2 2.9	Pd1 2	Pd2 3	Turns on Motor Pulley						
Open			Closed												
BLOWER PULLEY	DATUM DIAMETER	PITCH DIAMETER	5	4 1/2	4	3 1/2	3	2 1/2	2	1 1/2	1	1/2	0		
AK114	11	11.2	308	323	339	354	370	385	400	416	431	447	462		
1/3 to 2 HP AX BELTS			MOTOR PULLEY 1VL40		Dd1 2.4	Dd2 3.4	Pd1 2.6	Pd2 3.6	Turns on Motor Pulley						
Open			Closed												
BLOWER PULLEY	DATUM DIAMETER	PITCH DIAMETER	5	4 1/2	4	3 1/2	3	2 1/2	2	1 1/2	1	1/2	0		
AK114	11	11.2	400	416	431	447	462	477	493	508	524	539	554		
AK94	9	9.2	488	506	525	544	563	581	600	619	638	656	675		
AK79	7.5	7.7	582	605	627	650	672	694	717	739	762	784	806		
AK66	6.2	6.4	701	728	755	782	809	836	863	889	916	943	970		
AK54	5	5.2	863	896	929	962	995	1028	1062	1095	1128	1161	1194		
AK46	4.2	4.4	1019	1059	1098	1137	1176	1215	1255	1294	1333	1372	1411		
AK39	3.5	3.7	1212	1259	1305	1352	1399	1445	1492	1539	1585	1632	1678		
AK32	3	3.2	1402	1455	1509	1563	1617	1671	1725	1779	1833	1887	1941		
3 to 5 HP BX BELTS			MOTOR PULLEY 2VP42		Dd1 2.9	Dd2 3.9	Pd1 3	Pd2 4	Turns on Motor Pulley						
Open			Closed												
BLOWER PULLEY	DATUM DIAMETER	PITCH DIAMETER	6	5 1/2	5	4 1/2	4	3 1/2	3	2 1/2	2	1 1/2	1	1/2	0
2BK160H	15.4	15.7	330	339	348	357	366	375	385	394	403	412	421	430	439
2BK140H	13.4	13.7	378	388	399	409	420	430	441	451	462	472	483	493	504
2BK120H	11.4	11.7	442	455	467	479	491	504	516	528	541	553	565	577	590
2BK110H	10.4	10.7	484	497	511	524	537	551	564	578	591	605	618	631	645
2BK100H	9.4	9.7	534	548	563	578	593	608	622	637	652	667	682	697	711
2BK90H	8.4	8.7	595	611	628	644	661	677	694	710	727	744	760	777	793
2BK80H	7.4	7.7	672	691	709	728	747	765	784	803	821	840	859	877	896
2BK70H	6.4	6.7	772	794	815	837	858	880	901	923	944	965	987	1008	1030
2BK60H	5.4	5.7	908	933	958	984	1009	1034	1059	1084	1110	1135	1160	1185	1211
2BK55H	4.9	5.2	995	1023	1050	1078	1106	1133	1161	1189	1216	1244	1272	1299	1327
2BK50H	4.4	4.7	1101	1132	1162	1193	1223	1254	1285	1315	1346	1376	1407	1438	1468
7-1/2 to 10 HP BX BELTS			MOTOR PULLEY 2VP60		Dd1 4.3	Dd2 5.5	Pd1 4.7	Pd2 5.9	Turns on Motor Pulley						
Open			Closed												
BLOWER PULLEY	DATUM DIAMETER	PITCH DIAMETER	6	5 1/2	5	4 1/2	4	3 1/2	3	2 1/2	2	1 1/2	1	1/2	0
2BK160H	15.4	15.7	516	527	538	549	560	571	582	593	604	615	626	637	648
2BK140H	13.4	13.7	592	604	617	630	642	655	667	680	693	705	718	730	743
2BK120H	11.4	11.7	693	708	722	737	752	767	781	796	811	826	840	855	870
2BK110H	10.4	10.7	758	774	790	806	822	838	854	871	887	903	919	935	951
2BK100H	9.4	9.7	836	854	871	889	907	925	943	960	978	996	1014	1031	1049
2BK90H	8.4	8.7	932	952	972	991	1011	1031	1051	1071	1091	1110	1130	1150	1170
2BK80H	7.4	7.7	1053	1075	1098	1120	1143	1165	1187	1210	1232	1255	1277	1299	1322
3 to 5 HP BX BELTS			MOTOR PULLEY 2VP42		Dd1 2.9	Dd2 3.9	Pd1 3	Pd2 4	Turns on Motor Pulley						
Open			Closed												
BLOWER PULLEY	DATUM DIAMETER	PITCH DIAMETER	6	5 1/2	5	4 1/2	4	3 1/2	3	2 1/2	2	1 1/2	1	1/2	0
2BSV278	27.8	28.1	184	189	194	200	205	210	215	220	225	230	235	240	246
2BSV250	25	25.3	205	210	216	222	227	233	239	244	250	256	261	267	273
2BSV234	23.4	23.7	218	224	230	237	243	249	255	261	267	273	279	285	291
2BSV200	20	20.3	255	262	269	276	283	290	297	304	312	319	326	333	340
2BSV184	18.4	18.7	277	284	292	300	307	315	323	331	338	346	354	361	369
2BSV160	16	16.3	317	326	335	344	353	362	370	379	388	397	406	414	423
2BSV154	15.4	15.7	330	339	348	357	366	375	385	394	403	412	421	430	439
2BSV136	12.6	12.9	401	412	423	435	446	457	468	479	490	501	513	524	535
2BSV124	12.4	12.7	407	419	430	441	453	464	475	487	498	509	521	532	543
2BSV110	11	11.3	458	471	483	496	509	522	534	547	560	572	585	598	611
7-1/2 to 10 HP BX BELTS			MOTOR PULLEY 2VP60		Dd1 4.3	Dd2 5.5	Pd1 4.7	Pd2 5.9	Turns on Motor Pulley						
Open			Closed												
BLOWER PULLEY	DATUM DIAMETER	PITCH DIAMETER	6	5 1/2	5	4 1/2	4	3 1/2	3	2 1/2	2	1 1/2	1	1/2	0
2BSV278	27.8	28.1	289	295	301	307	313	319	325	331	338	344	350	356	362
2BSV250	25	25.3	320	327	334	341	348	355	361	368	375	382	389	395	402
2BSV234	23.4	23.7	342	349	357	364	371	378	386	393	400	408	415	422	429
2BSV200	20	20.3	399	408	416	425	433	442	450	459	467	476	484	493	501
2BSV184	18.4	18.7	434	443	452	461	470	480	489	498	507	517	526	535	544
2BSV160	16	16.3	497	508	519	529	540	550	561	571	582	593	603	614	624
2BSV154	15.4	15.7	516	527	538	549	560	571	582	593	604	615	626	637	648
2BSV136	12.6	12.9	628	642	655	669	682	695	709	722	735	749	762	776	789
2BSV124	12.4	12.7	638	652	666	679	693	706	720	733	747	761	774	788	801
2BSV110	11	11.3	717	733	748	763	779	794	809	824	840	855	870	885	901
15 to 20 HP BX BELTS			MOTOR PULLEY 2VP75		Dd1 5.8	Dd2 7	Pd1 6.2	Pd2 7.4	Turns on Motor Pulley						
Open			Closed												
BLOWER PULLEY	DATUM DIAMETER	PITCH DIAMETER	6	5 1/2	5	4 1/2	4	3 1/2	3	2 1/2	2	1 1/2	1	1/2	0
2BSV278	27.8	28.1	381	387	393	399	405	411	417	424	430	436	442	448	454
2BSV250	25	25.3	423	430	436	443	450	457	464	470	477	484	491	498	505
2BSV234	23.4	23.7	451	459	466	473	480	488	495	502	509	517	524	531	539
2BSV200	20	20.3	527	535	544	552	561	569	578	586	595	603	612	620	629
2BSV184	18.4	18.7	572	581	590	600	609	618	627	636	646	655	664	673	683
2BSV160	16	16.3	656	667	677	688	698	709	720	730	741	751	762	773	783
2BSV154	15.4	15.7	681	692	703	714	725	736	747	758	769	780	791	802	813
2BSV136	12.6	12.9	829	842	856	869	883	896	909	923	936	949	963	976	990

** 2HP Motors on 20 IN Blowers use 2VP42 Pulleys

Re-Circulating Control Options

Manual Positioning Control (Potentiometer)

The dampers can be controlled at a remote location by a manual potentiometer to any position from 20% to 100% fresh air. This will allow manually setting the dampers to match the building ventilation requirements. It will take an extra 3 control wires at the remote location. On a power failure, or if the unit is turned off, the return air damper will close by spring return.

Two Position Control

The dampers can be controlled by a two position switch (a field supplied switching device) to open the fresh air to 100%. On opening of the circuit, power failure, or if the unit is shutoff, the return air damper will close by spring return.

Building Signal Damper Control

When this option is ordered, the supply and return dampers will modulate based on a 0-10V DC signal from the Building Automation System.

Static Pressure Control (Photohelic)

The dampers can be controlled by a building static pressure control. This controller will sense the difference between pressure inside the building and pressure outside the building (sensed at the A-306 outdoor sensor) and will position the dampers to maintain the pressure setting on the controller. The controller has two setpoints and an indicator. The two setpoints are a minimum desired static pressure point and a maximum static pressure point.

The actual building static pressure will be shown by a visual indicator between these two settings. The controller will modulate the dampers to maintain a static pressure between these setpoints.

When the building's static pressure is below the minimum setting, the damper motor will proportionally open the fresh air damper and close the return air damper until static increases above the minimum setting. At this point, the damper motor will stop and hold this proportion.

If the building's static pressure continues to climb and goes above maximum setting, the damper motor will reverse proportion, closing the fresh air damper and opening the return air damper until static drops below maximum setting.

During the "OFF" or "Night" cycle of the unit, an internal switching circuit will close the return air damper.

See additional wiring and installation information on the static pressure controller and A-306 outdoor sensor.

Figure 16 - Photohelic Gauge

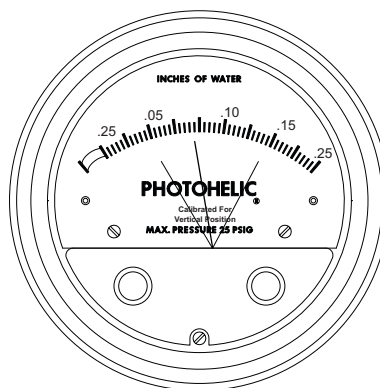

Static Pressure Controller Installation Instructions

Avoid locating the front of the static pressure controller in sun light or other areas with high ambient light or corrosive levels. Bright light shining on the photocells can cause false actuation of the load relays. The static pressure controller should be zeroed out before attaching the low and high pressure hoses. The zero adjustment is located between the minimum and maximum dials.

Using the supplied rubber tubing, plumb the high side of the static pressure controller to the inside of the building. The low side of the static pressure controller should be plumbed to the A-306 outdoor sensor. See the A-306 installation instructions.

Figure 17 - Static Pressure Controller

1. High Pressure Port
2. Low Pressure Port
3. Low Pressure to A-306 Outdoor Sensor
4. High Pressure to the Building

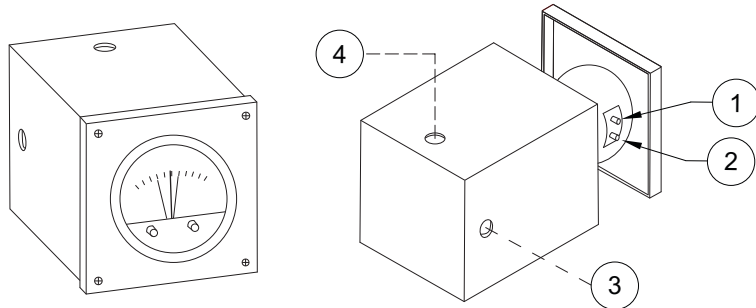

A-306 Outdoor Sensor

Use the installation instructions shipped with the A-306 Outdoor Sensor.

Figure 18 - A-306 Outdoor Sensor

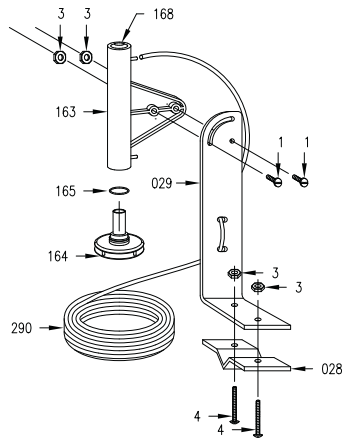
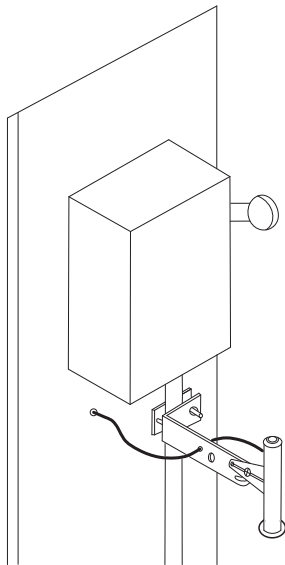

Item Number	Description
1	10-32 x 1/2" Machine Screw (2)
3	10-32 Nut (4)
4	10-32 x 1-3/4" Machine Screw (2)
028	Antenna Clamp
029	Mounting Bracket
163	Pick Up Body
164	Static Pressure Plates
165	"O" Ring Seal
168	Hole Plug
290	Tubing - 50'

TROUBLESHOOTING

The troubleshooting section lists causes and corrective actions for possible problems with the equipment. Review this section prior to consulting the manufacturer.

Airflow Troubleshooting Chart

Problem	Potential Cause	Corrective Action
Fan Inoperative	Blown fuse/Open circuit breaker	Check amperage.
		Check fuse, replace if needed.
		Check circuit breaker.
	Disconnect switch in "OFF" position	Place switch to the "ON" position.
	Incorrect wiring to motor	Inspect motor wiring. Verify connections with wiring diagram located on fan motor.
Motor starter overloaded	Check amperage.	
	Reset starter.	
Motor Overload	Incorrect fan rotation	Verify that the fan is rotating in the direction shown on rotation label.
	Fan speed is too high	Reduce fan RPM.
	Incorrect wiring to motor	Inspect motor wiring. Verify connections with wiring diagram located on fan motor.
	Overload in starter set too low	Set overload to motor's FLA value.
	Motor HP too low	Determine if HP is sufficient for job.
	Duct static pressure lower than design	Reduce fan RPM.
Insufficient Airflow	Incorrect fan rotation	Verify that the fan is rotating in the direction shown on rotation label.
	Poor outlet conditions	Check duct and connections. There should be a straight duct connection to the outlet.
	Intake damper not fully open	Inspect damper linkage. If the linkage is damaged, replace damper motor.
	Duct static pressure higher than design	Check ductwork. Adjust/resize to eliminate or reduce duct losses.
	Blower speed too low	Increase fan RPM. Do not overload motor.
	Supply grills or registers closed	Open/Adjust.
	Dirty/clogged filters	Clean filters. Replace filters if they cannot be cleaned or are damaged.
Excessive Airflow	Fan speed is too high	Reduce fan RPM.
	Filters not installed	Install filters.
	Duct static pressure lower than design	Reduce fan RPM.
Excessive Vibration and Noise	Damaged/Unbalanced wheel	Replace wheel.
	Fan is operating in unstable region of fan curve	Refer to performance curve for fan.
	Fan speed is too high	Reduce fan RPM.

MSC Troubleshooting

Fault	Problem	Potential Cause	Corrective Action
Feedback Fault	Feedback Fault on MSC Display	Disconnected/faulty wiring	Secure connections to fan. If faulty wiring is found, repair or replace as required.
		No feedback for 30 seconds	Check parameters.
		Less than 70% of RPM	Check duct/fan for obstructions.
Modbus	Modbus fault on MSC Display	Faulty Cat 5 connection/cable	Find and replace faulty cable.
		ECPM03 does not recognize device	Verify Modbus # on device is set correctly.
Variable Device Fault	Motor not responding to changes made on variable device (potentiometer)	Defective potentiometer	Replace potentiometer.
		Faulty wiring to motor	Find and replace faulty wiring.
Motor not responding	Motor not functioning as expected	2-Speed switch not working	Check switch and wiring.
		Wiring to motor defective	Find and replace faulty wiring.
		Check for other faults on MSC display	If no other faults are present, motor may be defective.

TURN OFF POWER TO THE MOTOR WHILE PROGRAMMING THIS DEVICE.

- If the device has a potentiometer or a 2-Speed switch, a jumper wire can be placed in between the 10V In and 10V Out terminals to rule out a defective device. This will cause the motor to go to HIGH SPEED.
- The IO STATUS menu can be used to verify the inputs and outputs of the device are functioning as expected.
- The FAULT HISTORY menu can be used to keep track of faults while working on the device.

MAINTENANCE

To guarantee trouble-free operation of this fan, the manufacturer suggests following these guidelines. Most problems associated with fan failures are directly related to poor service and maintenance.

Please record any maintenance or service performed on this fan in the documentation section located at the end of this manual.

WARNING: DO NOT ATTEMPT MAINTENANCE ON THE FAN UNTIL THE ELECTRICAL SUPPLY IS COMPLETELY DISCONNECTED.

General Maintenance

- Fan inlet and approaches to ventilator should be kept clean and free from any obstruction.
- All fasteners and electrical connections should be checked for tightness each time maintenance checks are performed before restarting unit.
- These units require very little attention when moving clean air. Occasionally oil and dust may accumulate, causing imbalance. If the fan is installed in a corrosive or dirty atmosphere, periodically inspect and clean the wheel, inlet, and other moving parts to ensure smooth and safe operation.
- Motors are normally permanently lubricated. **CAUTION: Use care when touching the exterior of an operating motor. Components may be hot enough to burn or cause injury.**
- If bearings require lubrication, very little is needed. A general rule is one-half pump from a grease gun for 1/2" to 1-7/16" shaft diameters and one full pump for 1-11/16" and large diameter shafts for every 1500 to 3000 hours of operation. A lithium-based grease should be used. Bearings should be rotated as they are lubricated to evenly distribute the grease, either by hand or via extended grease lines. Do not attempt to grease bearings from inside the enclosure while the motor is energized. **CAUTION: Bearings are sealed, over-greasing can cause damage to the bearings. Do not grease until grease comes out of seals. Only add the appropriate amount of grease.**

2 Weeks After Start-up

- All fasteners should be checked for tightness each time maintenance checks are performed before restarting unit.

Every 3 Months

- Filters need to be cleaned and/or replaced quarterly, and more often in severe conditions. Washable filters can be washed in warm soapy water. When re-installing filters, be sure to install with the **airflow in the correct direction** as indicated on the filter.
- All fasteners should be checked for tightness each time maintenance checks are performed before restarting unit.

Yearly

- Inspect bolts and screws for tightness. Tighten as necessary.
- Inspect motor for cleanliness. Clean exterior surfaces only. Remove dust and grease from the motor housing to ensure proper motor cooling.
- Remove dirt and grease from the wheel and housing to prevent imbalance and damage.
- Inspect the unit assembly. Check all modules, curbs, and mounting equipment (rails/Uni-Strut).

Unit Filters

Table 8 - Filter Quantity Chart

Intake	16" x 20"	20" x 25"
Size 1 Standard Sloped	2	-
Size 2 Standard Sloped	-	2
Size 1 Modular Sloped	3	-
Size 2 Modular Sloped	-	3
Size 3 Modular Sloped	6	-
Size 4 Modular Sloped	10	-
Size 5 Modular Sloped	-	8
Size 1 V-Bank	-	3
Size 2 V-Bank	8	-
Size 3 V-Bank	-	8
Size 4 V-Bank	15	-
Size 5 V-Bank	-	12
Size 1 Inline	1	-
Size 2 Inline	-	1
Size 3 Inline	-	2

Optional Mixing Box Filters

Table 9 - Diagonal Filters

Unit Size	Quantity	Size
1	4	10" x 16"
2	2	20" x 25"
3	4	15" x 20"
4	4	18" x 25"
5	9	14.5" x 19"

Table 10 - Vertical Filters

Unit Size	Quantity	Size
1	1	10" x 16"
2	1	16" x 25"
3	2	15" x 15"
4	2	16" x 20"
5	3	14.5" x 19"

Start-up and Maintenance Documentation

START-UP AND MEASUREMENTS SHOULD BE PERFORMED AFTER THE SYSTEM HAS BEEN AIR BALANCED (Warranty will be void without completion of this form)

Job Information

Job Name		Service Company	
Address		Address	
City		City	
State		State	
Zip		Zip	
Phone Number		Phone Number	
Fax Number		Fax Number	
Contact		Contact	
Purchase Date		Start-up Date	

Fan Unit Information

Refer to the start-up procedure in this manual to complete this section.

Name Plate and Unit Information		Blower Rotation	
Model Number		Correct	
Serial Number		Incorrect	
Volts		Field Measure Information	
Hertz		Voltage	
Phase		Amperage**	
FLA		RPM	
HP			
Blower Pulley			
Motor Pulley			
Belt Number			

**If measured amps exceed the FLA rating on the nameplate, fan RPM must be reduced to decrease the measured amps below the nameplate FLA rating.

As a result of our dedication to constant improvements and quality, the MANUFACTURER reserves the right to update specifications without notice. Please refer to MANUFACTURER’S website for up to date documentation.

Technical Support Information

CASLink



Technical Support



Parts Store

